

Collaborative National Program for the Development of Performance Testing Protocols for Distributed Generation with CHP

Presented by:

Mark Hanson
New York, NY
June 24, 2004

Presentation Outline

- Introduction
- Program Organizational Structure
- Laboratory and Field Protocol Outlines
- Case Study and Long Term Monitoring Protocols
- National Database
- Program Timetable
- Industry Adoption and Coordination

Introduction

- Partnership between US DOE and Association of State Energy Research and Technology Transfer Institutions (ASERTTI)
- Objective is nationally accepted performance testing protocols for micro-turbines, reciprocating engines, small turbines and in the future, fuel cells
- Develop an applications case study protocol
- Develop a long-term monitoring protocol
- Develop an online searchable database populated with DG performance results in lab and field

Mark Hanson
Director of State Relations

Organizational Structure-1

Steering Committee Composed of Sponsors

California Energy Commission

Energy Center of Wisconsin

Illinois Department of Commerce and
Economic Opportunity

National Renewable Energy Laboratory

NYSERDA

U.S. Department of Energy

Organizational Structure-2

Stakeholders Advisory Committee

- Manufacturers and distributors
- End users (owners) and operators
- Utilities, researchers including National Labs, public interest groups, and governmental including U.S. EPA

■ Subcontractors

- Laboratory protocol– Gas Technology Institute w/ UL
- Field protocol– Southern Research Institute
- Case study protocol– University of Illinois at Chicago – Energy Research Center
- Long term monitoring protocol- Connected Energy Corporation

Organization Chart

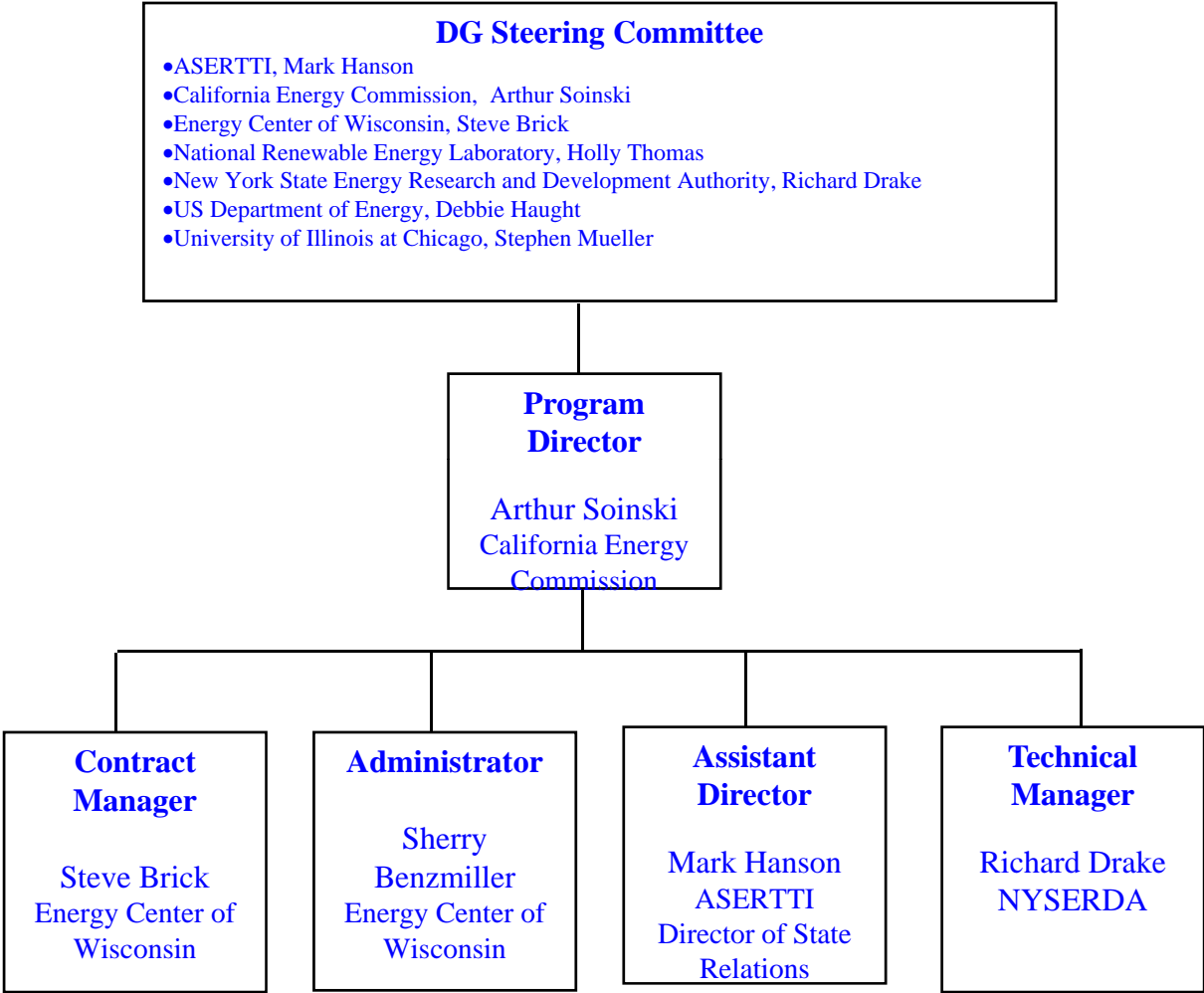

Mark Hanson
Director of State Relations

Field Testing Protocol Outline

- Scope and Purpose
- DG/CHP System Boundaries
- Electrical Generation Performance
- Electrical Generation Efficiency
- CHP Thermal and Total Efficiency
- Atmospheric Emissions Performance
- Acoustic Emissions Performance
- Appendices and Forms

System Boundaries

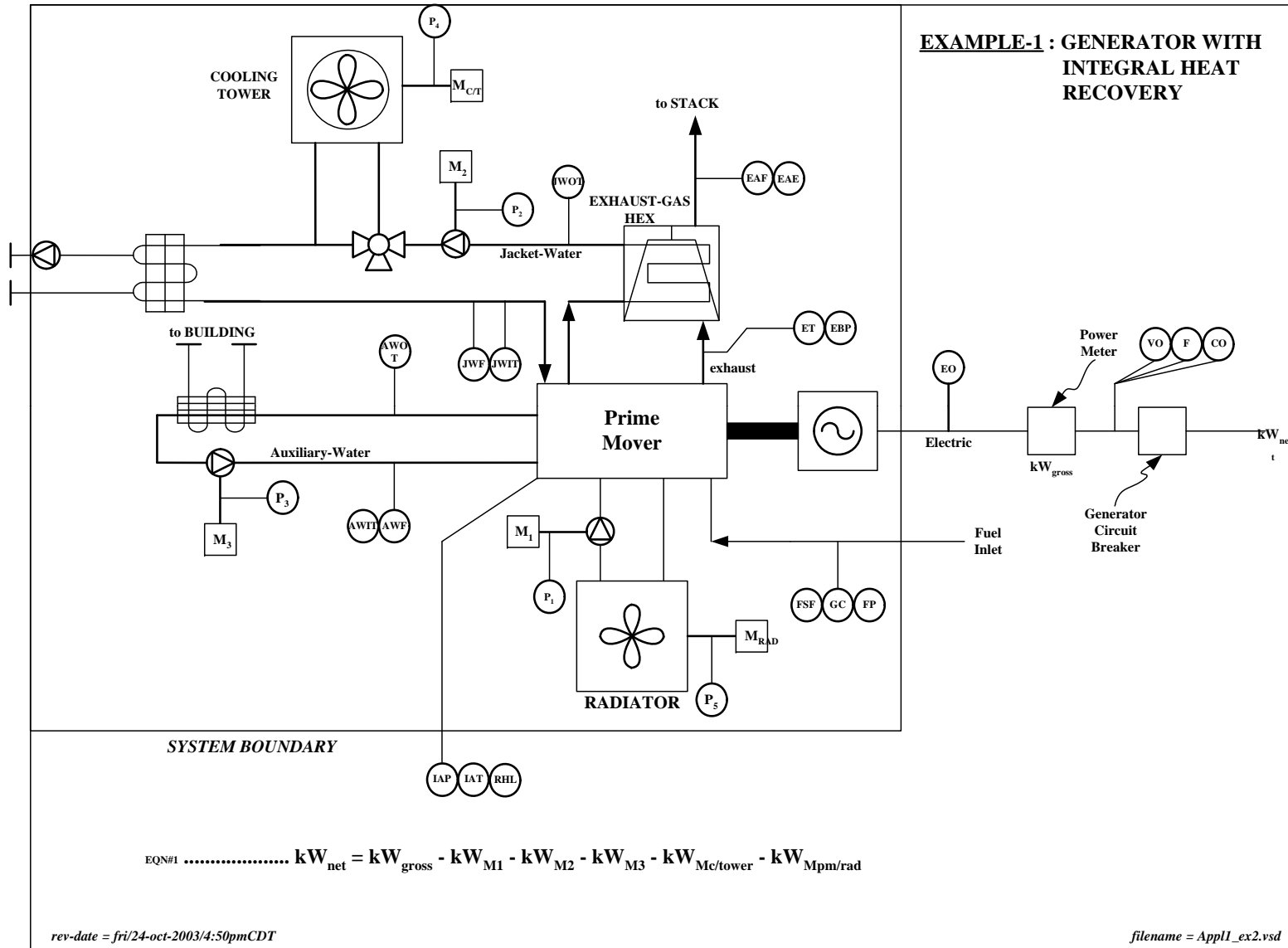

Mark Hanson
 Director of State Relations

Micro-turbine Generator

Power Output v. Intake Air Temperature

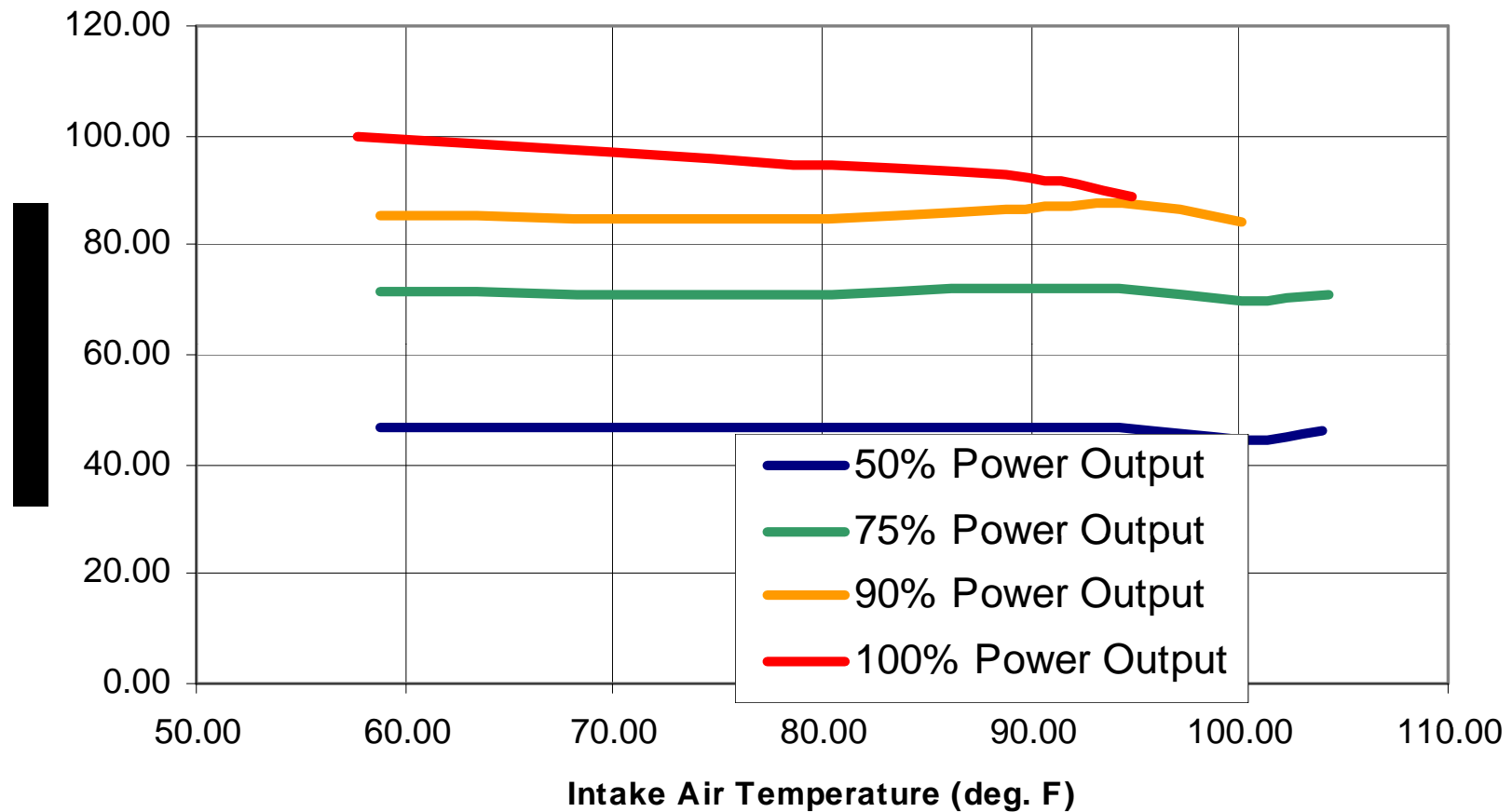

Mark Hanson
Director of State Relations

Reciprocating Engine

System Efficiency v. Water Inlet Temperature
(As a function of power output)

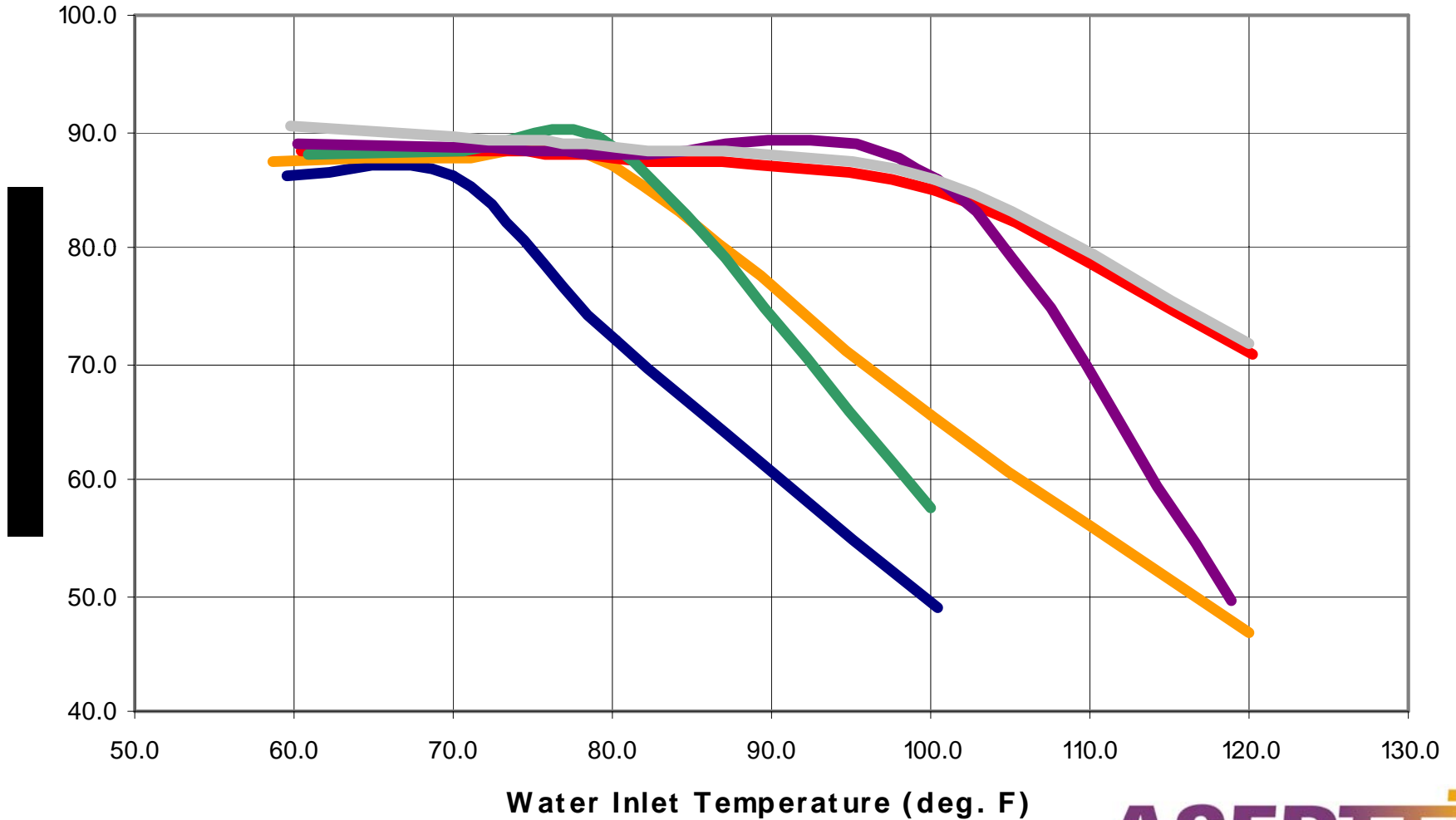

Mark Hanson
Director of State Relations

Micro-turbine Generator

NO_x Emissions v. Intake Air Temperature

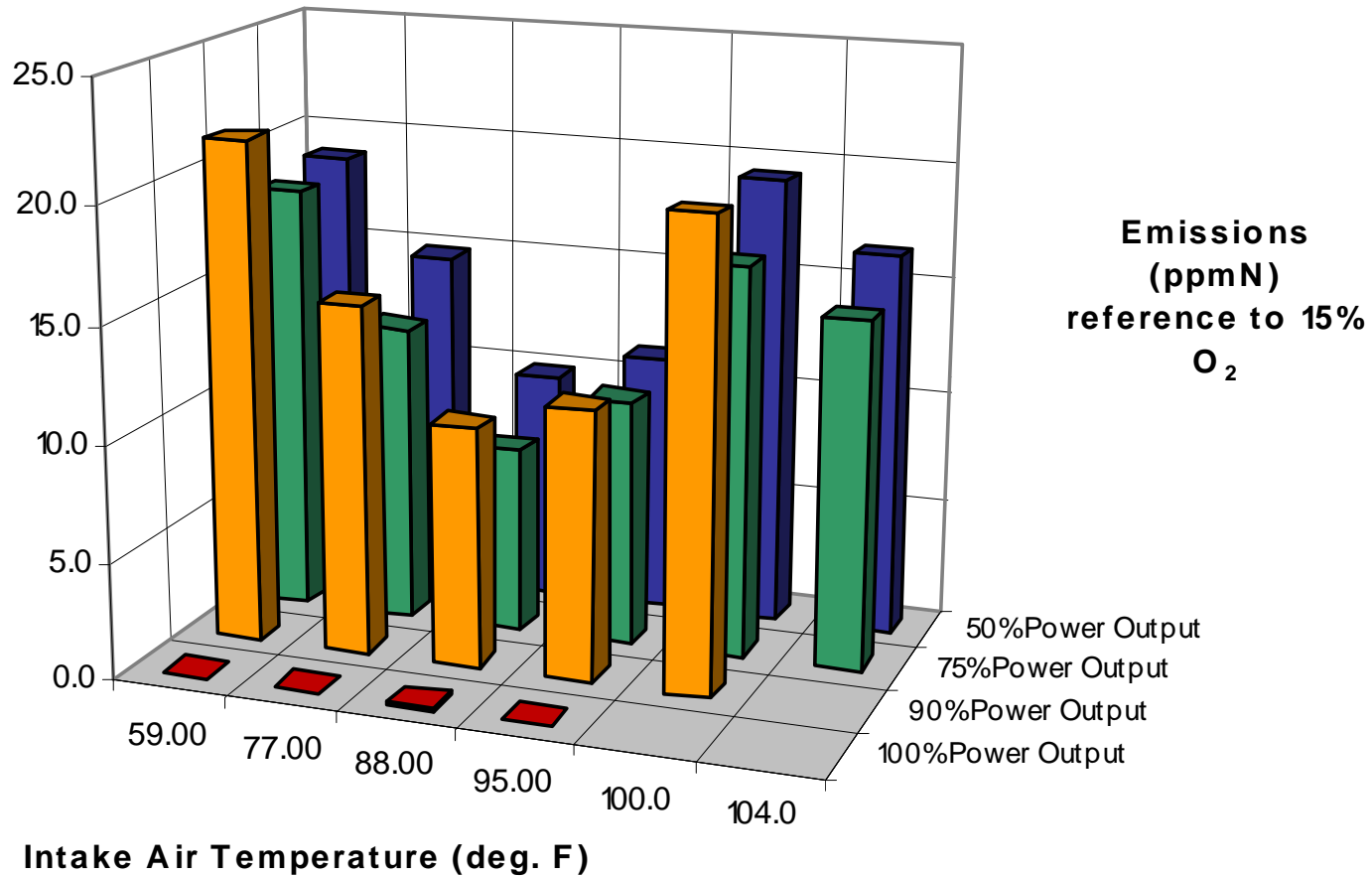

Mark Hanson
Director of State Relations

Lab, Field, Long Term Monitoring and Case Study Protocols

- Specific to performance parameters
- Affordability is a critical feature to support widespread adoption
- Lab protocol up to 3 MW with laboratory level control and greater accuracy
- Field protocol up to 7 MW
- Case study protocol describes application and field results including economic performance

Timetable for Program-Phase 1

- September 2003 Stakeholder Advisory Committee meeting
- Final draft protocols reviewed by SAC March 25th
- Microturbine, IC, and Small Turbine Interim Protocols published July 2004
- Second phase funding finalized summer 2004
- Field validation in summer and fall 2004
- NREL Database Start-up Summer 2004

Mark Hanson
Director of State Relations

Timetable for Program-Phase 2

- Database at NREL on-line beginning fall 2004 and continues through 2007
- Work commences on Fuel Cell protocol in fall 2004
- SAC meeting to review final MTG, IC, and Small Turbine protocols, validation results, and database design in late 2004
- Fuel Cell protocols drafted for SAC review in spring 2005
- Interim Fuel Cell Protocol Published Summer 2005

Timetable for Phase-2 (cont.)

- Fuel Cell protocol validation testing fall 2005
- Database operation and expansion continuing through 2007
- Planning for long term Database support

Industry Adoption and Coordination

- Manufacturers' use of lab protocol is critical to populating the database
- End User/ASERTTI/DOE field protocol use is critical to populating the database
- End User confidence in database is critical to marketplace adoption
- Database will include access to long-term project monitoring

Contacts

■ Richard Drake

NYSERDA

E-mail: rld@nyserda.org

Phone: 518-862-1090 x 3258

■ Mark Hanson

ASERTTI, Director of State Relations

E-mail: MHanson@hoffman.net

Phone 608 692-1915

■ Arthur Soinski

California Energy Commission

E-mail: asoinski@energy.state.ca.us

Phone 916 654-4674

Mark Hanson
Director of State Relations