

**DEVELOPMENT OF FINE PARTICULATE EMISSION FACTORS AND
SPECIATION PROFILES FOR OIL- AND GAS-FIRED COMBUSTION
SYSTEMS**

TOPICAL REPORT: FINE PARTICULATE TEST PROTOCOL



When citing this document, please use the following citation:
England, G.C. and McGrath, T.P., “Development of Fine Particulate Emission Factors and Speciation Profiles for Oil and Gas-fired Combustion Systems, Topical Report: Fine Particulate Test Protocol”.

DEVELOPMENT OF FINE PARTICULATE EMISSION FACTORS AND SPECIATION PROFILES FOR OIL- AND GAS-FIRED COMBUSTION SYSTEMS

TOPICAL REPORT: FINE PARTICULATE TEST PROTOCOL

Prepared by:

Glenn C. England and Thomas P. McGrath
GE Energy and Environmental Research Corporation
18 Mason
Irvine, CA 92618

Prepared for:

National Petroleum Technology Office
National Energy Technology Laboratory
United States Department of Energy
(DOE Contract No. DE-FC26-00BC15327)

Gas Research Institute
California Energy Commission – Public Interest Energy Research (PIER)
New York State Energy Research and Development Authority
(GRI contract No. 8362)

American Petroleum Institute
(API Contract No. 00-0000-4303)

Draft (Revision 0): February 9, 2004
Final (Revision 0.1): March 30, 2004
Final (Revision 0.2): April 2, 2004

LEGAL NOTICES

United States Department of Energy:

This report was prepared as an account of work sponsored by an agency of the United States Government. Neither the United States Government nor any agency thereof, nor any of their employees, makes any warranty, express or implied, or assumes any legal liability or responsibility for the accuracy, completeness, or usefulness of any information, apparatus, product, or process disclosed, or represents that its use would not infringe privately owned rights. Reference herein to any specific commercial product, process, or service by trade name, trademark, manufacturer, or otherwise does not necessarily constitute or imply its endorsement, recommendation, or favoring by the United States Government or any agency thereof. The views and opinions of authors expressed herein do not necessarily state or reflect those of the United States Government or any agency thereof.

Gas Research Institute:

This report was prepared by GE EER as an account of contracted work sponsored by the Gas Research Institute (GRI). Neither GE EER, GRI, members of these companies, nor any person acting on their behalf:

- a. Makes any warranty or representation, expressed or implied, with respect to the accuracy, completeness, or usefulness of the information contained in this report, or that the use of any apparatus, methods, or process disclosed in this report may not infringe upon privately owned rights; or
- b. Assumes any liability with respect to the use of, or for damages resulting from the use of, any information, apparatus, method, or process disclosed in this report.

California Energy Commission:

This report was prepared as a result of work sponsored by the California Energy Commission (Commission). It does not necessarily represent the views of the Commission, its employees, or the State of California. The Commission, the State of California, its employees, contractors, and subcontractors make no warranty, express or implied, and assume no legal liability for the information in this report; nor does any party represent that the use of this information will not infringe upon privately owned rights. This report has not been approved or disapproved by the Commission nor has the Commission passed upon the accuracy or adequacy of the information in this report.

New York State Energy Research and Development Authority:

This report was prepared by GE Energy and Environmental Research Corporation in the course of performing work contracted for and sponsored by the New York State Energy Research and Development Authority (NYSERDA). The opinions expressed in this report do not necessarily reflect those of the NYSERDA or the State of New York, and reference to any specific product, service, process, or method does not constitute an implied or expressed recommendation or endorsement of it. Further, NYSERDA and the State of New York make no warranties or representations, expressed or implied, as to the fitness for particular purpose or merchantability of any product, apparatus, or service, or the usefulness, completeness, or accuracy of any processes, methods, or other information contained, described, disclosed, or referred to in this report. NYSERDA, the State of New York, and the contractor make no representation that the

use of any product, apparatus, process, method, or other information will not infringe privately owned rights and will assume no liability for any loss, injury, or damage resulting from, or occurring in connection with, the use of information contained, described, disclosed, or referred to in this report.

American Petroleum Institute:

API publications necessarily address problems of a general nature. With respect to particular circumstances, local state and federal laws and regulations should be reviewed.

API is not undertaking to meet the duties of employers, manufacturers, or suppliers to warn and properly train and equip their employees, and others exposed, concerning health and safety risks and precautions, nor undertaking their obligations under local, state, or federal laws. Nothing contained in any API publication is to be construed as granting any right, by implication or otherwise, for the manufacture, sale, or use of any method, apparatus, or product covered by letters patent. Neither should anything contained in the publication be construed as insuring anyone against liability for infringement of letters patent.

GE Energy and Environmental Research Corporation

This report was prepared by GE Energy & Environmental Research Corporation (as part of GE Power Systems and GE, collectively hereinafter “EER”) as an account of sponsored work. EER, nor any of their employees, makes any warranty, express or implied or otherwise, or assumes any legal liability or responsibility of the accuracy, completeness, or usefulness of any information, apparatus, processes, systems, products, methodology or the like disclosed herein, or represents that its use would not infringe privately owned rights. Reference herein to any specific commercial product process or service by trade name, trademark, manufacturer, or otherwise does not necessarily constitute or imply an endorsement, recommendation, or favoring by EER. The views and opinions of the authors expressed herein do not necessarily state or reflect those of EER. This report has not been approved or disapproved, endorsed or otherwise certified by EER nor has EER passed upon the accuracy or adequacy of the information in this report.

ACKNOWLEDGEMENTS

The following people are recognized for their contributions of time and expertise during this study and in the preparation of this report:

GE ENERGY AND ENVIRONMENTAL RESEARCH CORPORATION

PROJECT TEAM MEMBERS

Glenn England, Project Manager
Stephanie Wien, Project Engineer
Dr. Oliver M.C. Chang, Project Engineer
Prof. Judith Chow, Desert Research Institute
Prof. John Watson, Desert Research Institute
Prof. Barbara Zielinska, Desert Research Institute
Prof. Lynn Hildemann, Stanford University
Prof. Philip Hopke, Clarkson University

AD HOC COMMITTEE MEMBERS

Dr. Karl Loos, Shell Global Solutions
Prof. James Schauer, University of Wisconsin-Madison
Dr. Praveen Amar, NESCAUM
Thomas Logan, U.S. EPA
Ron Myers, U.S. EPA
Karen Magliano, California Air Resources Board

PROJECT SPONSORS

Kathy Stirling, U.S. Department of Energy National Petroleum Technology Office
Marla Mueller, California Energy Commission
Dr. Paul Drayton, Gas Research Institute
Karin Ritter, American Petroleum Institute
Barry Liebowitz, New York State Energy Research and Development Authority
Janet Joseph, New York State Energy Research and Development Authority

FOREWORD

In 1997, the United States Environmental Protection Agency (EPA) promulgated new National Ambient Air Quality Standards (NAAQS) for particulate matter, including for the first time particles with aerodynamic diameter smaller than 2.5 micrometers (PM_{2.5}). PM_{2.5} in the atmosphere also contributes to reduced atmospheric visibility, which is the subject of existing rules for siting emission sources near Class 1 areas and new Regional Haze rules. There are few existing data regarding emissions and characteristics of fine aerosols from oil, gas and power generation industry combustion sources, and the information that is available is generally outdated and/or incomplete. Traditional stationary source air emission sampling methods tend to underestimate or overestimate the contribution of the source to ambient aerosols because they do not properly account for primary aerosol formation, which occurs after the gases leave the stack. These deficiencies in the current methods can have significant impacts on regulatory decision-making. The current program was jointly funded by the U.S. Department of Energy National Petroleum Technology Office (DOE/NPTO), California Energy Commission CEC), Gas Research Institute (GRI), New York State Energy Research and Development Authority (NYSERDA) and the American Petroleum Institute (API) to provide improved measurement methods and reliable source emissions data for use in assessing the contribution of oil, gas and power generation industry combustion sources to ambient PM_{2.5} concentrations. More accurate and complete emissions data generated using the methods developed in this program will enable more accurate source apportionment and source receptor analysis for PM_{2.5} NAAQS implementation and streamline the environmental assessment of oil, gas and power production facilities.

The goals of this program were to:

- Develop improved dilution sampling technology and test methods for PM_{2.5} mass emissions and speciation measurements, and compare results obtained with dilution and traditional stationary source sampling methods.
- Develop emission factors and speciation profiles for emissions of fine particulate matter, especially organic aerosols, for use in source-receptor and source apportionment analysis;
- Identify and characterize PM_{2.5} precursor compound emissions that can be used in source-receptor and source apportionment analysis; and

This report is part of a series of progress, topical and final reports presenting the findings of the program.

TABLE OF CONTENTS

LEGAL NOTICES.....	IV
ACKNOWLEDGEMENTS.....	VI
FOREWORD.....	VII
LIST OF FIGURES.....	X
TEST METHOD FOR DETERMINATION OF THE MASS AND SPECIATION OF PM _{2.5} EMISSIONS AND PRECURSORS FROM STATIONARY COMBUSTION SOURCES.....	1
Scope.....	1
Referenced Documents.....	1
ASTM Standards:.....	1
International Organization for Standardization (ISO) Standards:.....	2
Non-ASTM.....	2
Terminology.....	4
Definitions of Terms Specific to This Method.....	4
Summary of Test Method.....	6
Significance and Use.....	10
Interferences.....	10
Requirements for Sampling Plane and Sampling Points.....	12
Sampling Plane:.....	12
Minimum Number and Location of Sampling Points for measuring flue gas velocities:.....	13
Access Ports:.....	13
Velocity and Gas Composition Measurement Apparatus.....	13
Sampling Apparatus.....	13
Dilution sampling system mixer/residence time chamber – with following specifications:.....	14
PM _{2.5} Sampling System.....	15
Particulate Filter Analysis System.....	16
Reagents and Materials.....	16
Weighing and Pre-Sampling Procedure.....	17
General Aspects.....	17
Weighing Procedures:.....	18
Sampling.....	18
Preparation:.....	18
Pre-Sampling Measurements:.....	19
Sampling:.....	19
Recovery of Deposits Upstream of the Filter.....	21
Validation of Results.....	21
Leak Check:.....	21
Calibration and QA/QC Activities:.....	21
QA/QC Activities.....	22
Additional Aspects Discussion.....	23
Sampling Duration and Detection Limit:.....	23
Particulate Deposits Upstream of the Filter:.....	23
Improvement of the Weighing Procedure:.....	23

Calculations.....	24
Stack Gas Flow Rate.....	24
Calculated from tracer gas measurements	24
Calculated from direct flow measurements.....	24
PM2.5 Concentration in Stack Gas.....	25
PM2.5 Mass Emission Rate	25
Precision and Bias.....	25
General:.....	25
Test Report.....	26
Keywords	28
Safety Precautions.....	28

LIST OF FIGURES

Figure 1 (a). Filter Cartridge Assembly.....	7
Figure 1 (b) Filter Cartridge Assembly.....	8
Figure 2. Dilution sampling system schematic	9

TEST METHOD FOR DETERMINATION OF THE MASS AND SPECIATION OF PM_{2.5} EMISSIONS AND PRECURSORS FROM STATIONARY COMBUSTION SOURCES

SCOPE

This test method describes the sampling and conditioning of exhaust gas samples from stationary combustion sources by dilution sampling that approximately simulates conditions experienced by stack emissions as they mix with the atmosphere. This method measures mass concentrations of particles smaller than 2.5 micrometers aerodynamic diameter (PM_{2.5}). Optionally, the method also can be used to also measure mass concentrations of particles with aerodynamic diameter between 2.5 and 10 micrometers for determination of total particles smaller than 10 microns aerodynamic diameter (PM₁₀). Optionally, physical and chemical characterization of PM_{2.5} and gases also can be accomplished using the same sampler by applying additional pre-test cleaning procedures and additional sampling and analysis methods after diluting the sample (N1, N3, N4).

The limit of detection for PM_{2.5} mass is dependent on the sample gas volume, dilution ratio (dilution air flow rate/exhaust gas flow rate), and analytical method sensitivity. A PM_{2.5} limit of detection of approximately 7 µg/dscm +/- 50 percent has been achieved while testing a natural gas-fired power plant with 47 mm Teflon membrane filter and a 27 dry standard cubic meters (dscm) sample volume and a dilution ratio of approximately 20:1 (20 degrees Celsius standard temperature, 460 millimeters of mercury standard pressure).

This method does not purport to address all of the safety problems associated with its use. It is the responsibility of the user of this standard to establish appropriate safety and health practices and to determine the applicability of regulatory limitations prior to use. For more specific safety precautionary information, see Section 19.

REFERENCED DOCUMENTS

ASTM Standards:

D 1193 Specification for Reagent Water

D1356-00a Terminology Relating to Sampling and Analysis of Atmospheres¹

D 2986 Practice for Evaluation of Air Assay Media by the Monodisperse DOP (Dioctyl Phthalate) Smoke Test

D 3154 Test Method for Average Velocity in a Duct (Pitot Tube Method)¹

D 3631 Test Methods for Measuring Surface Atmospheric Pressure¹

C 3685/D 3685 M Test Methods for Sampling and Determination of Particulate Matter in Stack Gases

D 3670 Guide for Determination of Precision and Bias of Methods of Committee D-224

D 3796 Practice for Calibration of Type S Pitot Tubes

D 6331-98 Test Method for Determination of Mass Concentration of Particulate Matter from Stationary Sources at Low Concentrations (Manual Gravimetric Method)¹

D 6831 – 02 Standard Test Method for Sampling and Determining Particulate Matter in Stack Gases Using an In-Stack, Inertial Microbalance

E 1 Specification for ASTM Thermometers²

1. Annual Book of ASTM Standards, Vol. 11.03

2. Annual Book of ASTM Standards, Vol. 14.03

International Organization for Standardization (ISO) Standards:

ISO 5725 Precision of test methods — Determination of repeatability and reproducibility by inter-laboratory tests

ISO 8178-1 Reciprocating internal combustion engines – Exhaust emission measurement – Part 1: Test-bed measurement of gaseous and particulate exhaust emissions.

ISO 9096 Stationary source emissions — Determination of concentration and mass flow rate of particulate material in gas-carrying ducts. Manual gravimetric method

ISO 10780 Stationary source emissions — Measurement of velocity and volume flow rate of gas stream in ducts

Non-ASTM

N1. “Particulate Matter (PM_{2.5}) Speciation Document (Third Draft)” USEPA Monitoring and Quality Assurance Group. January 21, 1999.

- N2. “EPA Method 19 – Determination of Sulfur Dioxide Removal Efficiency and Particulate Matter, Sulfur Dioxide, and Nitrogen Oxides Emission Rates” 40 CFR, Part 60, Appendix A.
- N3. “Compendium of Methods for the Determination of Inorganic Compounds in Ambient Air” US EPA Office of Research and Development, EPA/625/R-96/010a, June 1999.
- N4. “Compendium of Methods for the Determination of Toxic Organic Compounds in Ambient Air” US EPA Office of Research and Development, EPA/625/R-96/010b, January 1999.
- N5 “Aerosol Technology: Properties, Behavior, and Measurement of Airborne Particles (Second Edition). Hinds, W. C., John Wiley & Sons (1999).
- N6 “EPA Method PRE 004 – Method for the Determination of PM10 and PM2.5 Emissions (Constant Sampling Rate Procedure),” December 3, 2002.
- N7 ”DOE Standard – Specification for HEPA Filters Used by DOE Contractors.” DOE_STD-3020-97, January 1997.
- N8 “Reagent Chemicals, American Chemical Society Specifications,” American Chemical Society, Washington, DC. For suggestions on the testing of reagents not listed by the American Chemical Society, see Analar Standards for Laboratory Chemicals, BDH Ltd., Poole, Dorset, U.K., and the United States Pharmacopeia and National Formulary, U.S. Pharmacopeial Convention, Inc. (USPC), Rockville, MD.
- N9 “Source Evaluation Society Safety Guidelines Book (First Edition). December 20, 2001.
- N10 “EPA Method 2 – Determination of Stack Gas Velocity and Volumetric Flow Rate (Type S Pitot)” 40 CFR, Part 60, Appendix A.
- N11 “EPA Method 1 – Sample and Velocity Traverses for Stationary Sources,” 40 CFR, Part 60, Appendix A.
- N12 “Measurement of ultrafine particle size distribution from stationary combustion sources of coal, oil, and natural gas, Chang, M.C, Yi, S., Hopke, P.K, England, G. C., Chow, J.C., Watson, J.G. To be submitted to Journal of Air and Waste Management Association.
- N13 “SCAQMD Method 100.1 – Instrumental Analyzer Procedures for Continuous Gaseous Emission Sampling” SCAQMD Source Test Manual, March 1989.
- N14 “Method 5 - Determination of Particulate Matter Emissions from Stationary Sources,” Appendix A, 40 CFR 60, U.S. EPA.
- N15 “Method 202 - Determination of Condensable Particulate Emissions from Stationary Sources,” Appendix M, 40 CFR 51, U.S. EPA.
- N 16 “§ 86.1310–2007 Exhaust gas sampling and analytical system for gaseous emissions from heavy-duty diesel-fueled engines and particulate emissions from all engines” 40 CFR 86 Subpart N Revisions

TERMINOLOGY

For definitions of terms used in this test method, refer to Terminology ASTM D 1356.

Definitions of Terms Specific to This Method

ambient air sample - QA sample collected by drawing unfiltered ambient air at the stationary source sampling location through the sampling media.

diluted exhaust gas - the combined exhaust gas sample and the dilution air, after mixing.

dilution air – ambient air that is filtered to remove solid particulate and organic compounds and then mixed with an exhaust gas sample in a dilution sampling system

dilution ratio – ratio of the dilution air flow rate through a dilution system to the exhaust gas sample flow rate through the system.

dilution sampling system – sampling equipment that dilutes stationary source exhaust gases with filtered ambient air to simulate the mixing and cooling processes in an exhaust plume.

exhaust gas sample – undiluted exhaust gas extracted from the flue gas duct or stack of a stationary source.

field blank – QA sample collected by assembling the dilution sampling equipment at the stationary source sampling location, performing a leak check, and then disassembling the equipment. No exhaust gas sample passes through the equipment.

F-factor – the ratio of combustion gas volume to heat input determined from fuel composition; determined by EPA Method 19 procedures.

filtration temperature – the temperature of the sample gas immediately downstream of the filter. (The filter temp measurement device location shall be within 2.5 cm of the filter (N16))

HEPA filter – High Efficiency Particulate Air Filter

PM_{2.5} – particulate matter with an aerodynamic diameter less than 2.5 micrometers and captured on a Teflon filter maintained at a temperature of not greater than 47 Deg C (N16) and a relative humidity of 20 percent or lower.

sampling point – the specific position in a source vent at which a sample is extracted.

dilution system blank – QA sample collected by assembling the dilution sampling equipment at the stationary source sampling location and then drawing only dilution air through the dilution system and sampling media.

weighing control procedures – quality control procedures utilized for detecting/correcting apparent mass variations due to climatic or environmental changes between pre- and post-sampling weighing series.

VOC – volatile organic compounds, defined as organic compounds present with a vapor pressure below their saturated vapor pressure at ambient air pressure and temperature.

Filter holder assembly. The filter holder assembly shall comply with the specifications set forth for ambient PM measurement in 40 CFR Part 50, Appendix L 7.3.5, figures L–25 and L–26, with the following exceptions: (A) The material shall be 302, 303, or 304 stainless steel instead of anodized aluminum.

The 2.84 cm diameter entrance to the filter holder may be adapted, using sound engineering judgment and leak free construction, to an inside diameter no smaller than 0.85 cm, maintaining the 12.5 degree angle from the inlet of the top filter holder to the area near the sealing surface of the top of the filter cartridge assembly. Figure N07–2 shows acceptable variation from the design in 40 CFR Part 50, Appendix L. Similar variations using sound engineering design are also acceptable provided that they provide even flow distribution across the filter media and a similar leak-free seal with the filter cartridge assembly. (C) If additional or multiple filter cartridges are stored in a particulate sampler as part of an automatic sequential sampling capability, all such filter cartridges, unless they are installed in the sample flow (with or without flow established) shall be covered or sealed to prevent communication of semi-volatile matter from filter to filter; contamination of the filters before and after sampling; or loss of volatile or semi-volatile particulate matter after sampling.

Filter cartridge assembly. The filter cartridge assembly (Figure 1) shall comply with the specifications set forth for ambient PM measurement in 40 CFR Part 50, Appendix L 7.3.5, figures L-27, L-28, and L-29, with the following exceptions:

In addition to the specified Delrin TM material, 302, 303, or 304 stainless steel, polycarbonate or acrylonitrile/butadiene/styrene (ABS) resin, or a combination of these materials may also be used. A bevel introduced on the inside diameter of the entrance to the filter cartridge, as used by some commercially available automated sequential particulate filter cartridge changers, is also acceptable (see Figure N07-3).

SUMMARY OF TEST METHOD

A schematic of a dilution sampling system is shown in Figure 2. A sample of exhaust gas from a stationary source vent is drawn through a PM_{2.5} cyclone (and optionally a PM₁₀ cyclone for simultaneous determination of total suspended particles, PM₁₀, and PM_{2.5}) and a heated probe to a dilution system where the sample gas is rapidly mixed with dilution air. The dilution ratio should be 20:1 unless higher dilution ratios are required to maintain the particle filter temperature at 47 Deg C (N16) or lower. The lowest dilution ratio commensurate with achieving the filter temperature limitation should be used under these circumstances. The dilution system approximately simulates the dilution and cooling processes that occur in the near field of an exhaust plume as it mixes with the atmosphere. These processes impact the homogeneous and heterogeneous nucleation of exhaust gas constituents. The diluted sample relative humidity should not exceed 70 percent because higher levels can significantly affect particle agglomeration and size distribution within the dilution sampling system and thereby change the mass of particles that penetrate the final PM_{2.5} cyclone. Dehumidification of the dilution air may be required. The diluted sample then flows through a “residence time section” to allow nucleation and condensation processes to complete. A minimum post-mixing residence time of 10 seconds is required (N12). The diluted and aged gas is pulled through a PM_{2.5} cyclone or cyclones to one or more sampling trains. Particulate matter is collected on a single stage Teflon membrane filter or equivalent and subsequently measured gravimetrically or by inertial microbalance – (D.6831-02). Stack gas flow rates required for determination of mass emissions

METRIC
mm

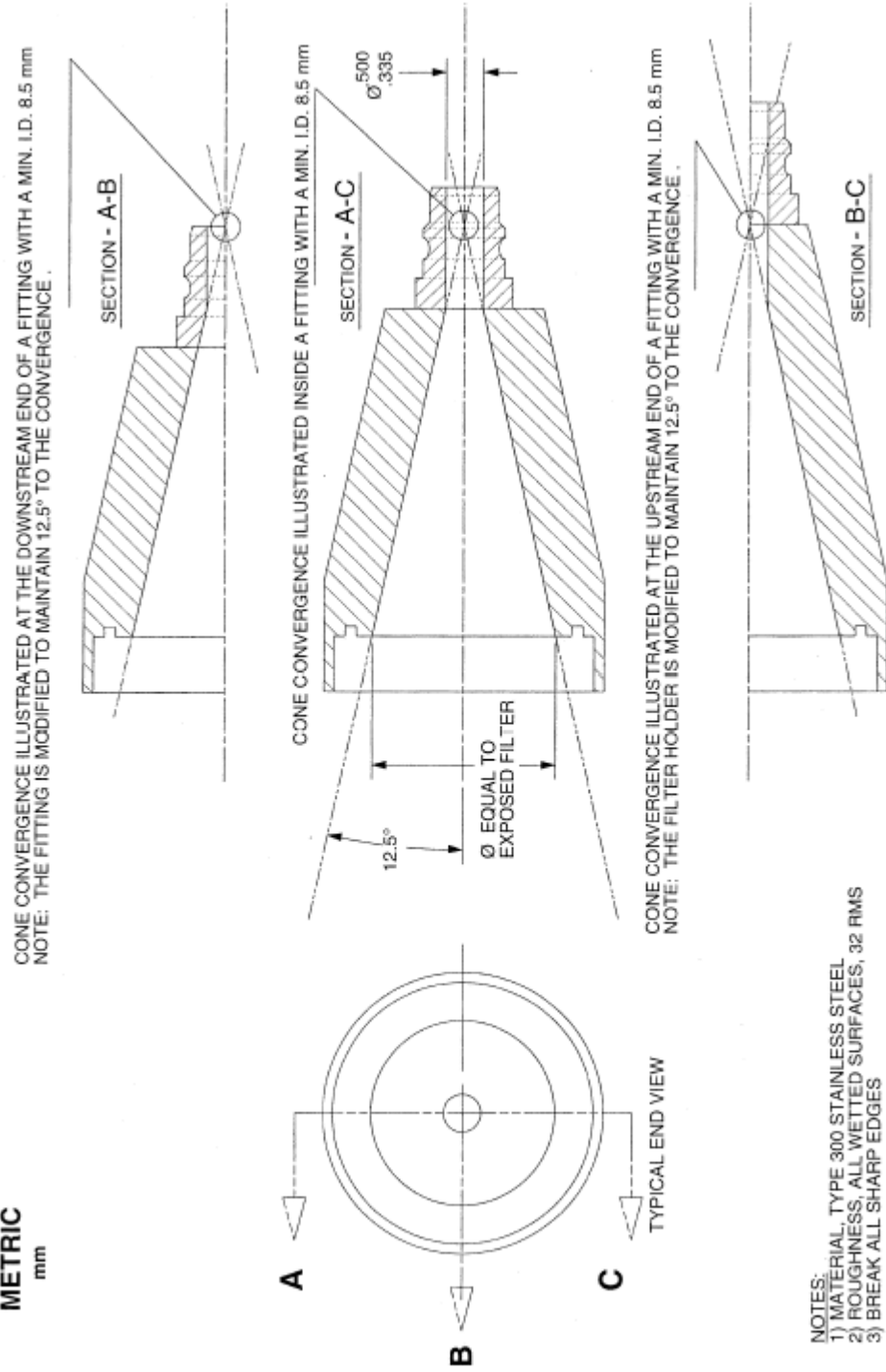

N07-2 FILTER HOLDER GEOMETRY

Figure 1 (a). Filter Cartridge Assembly.

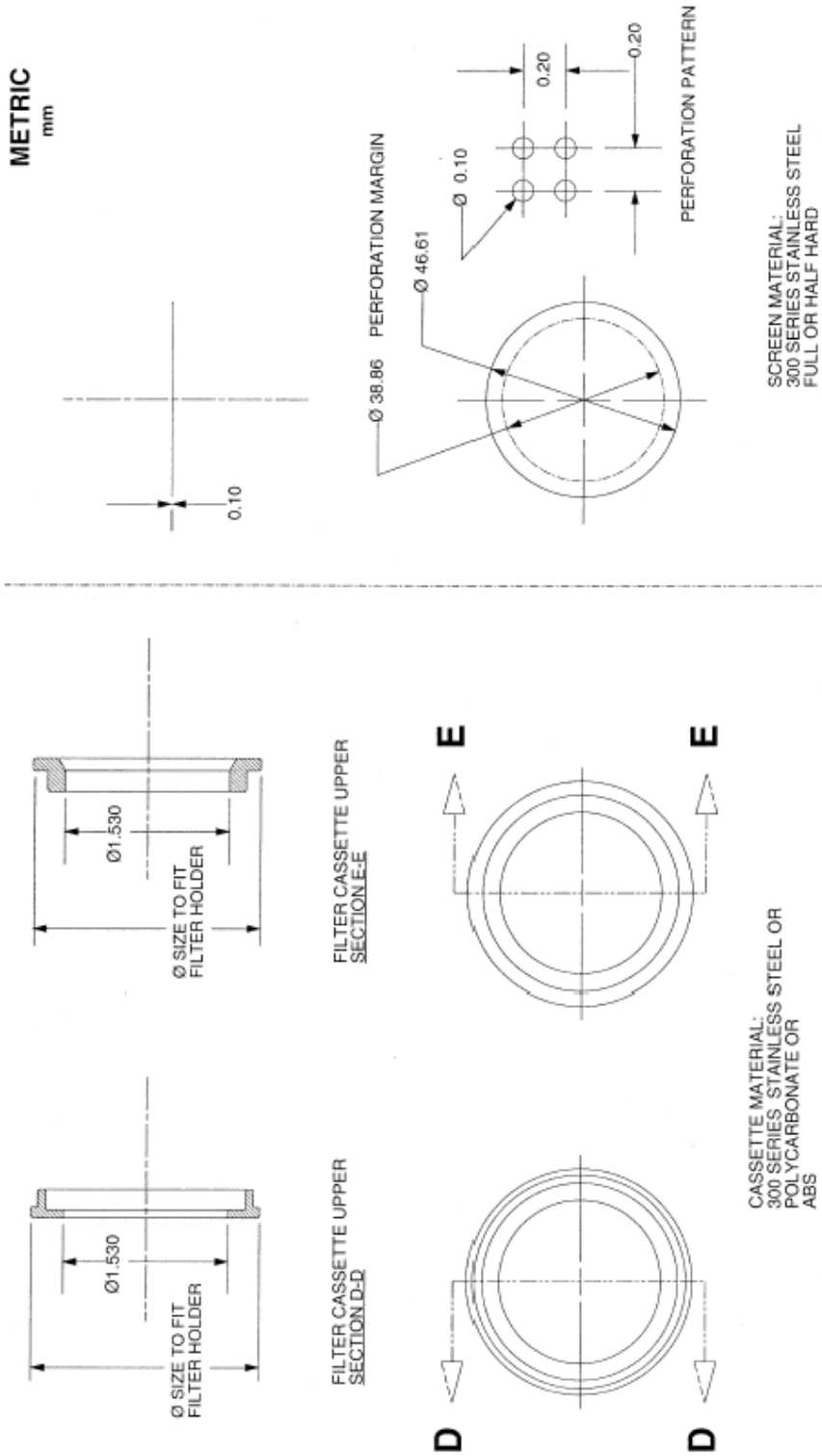

N07-3 FILTER CASSETTE AND SCREEN

Figure 1 (b) Filter Cartridge Assembly.

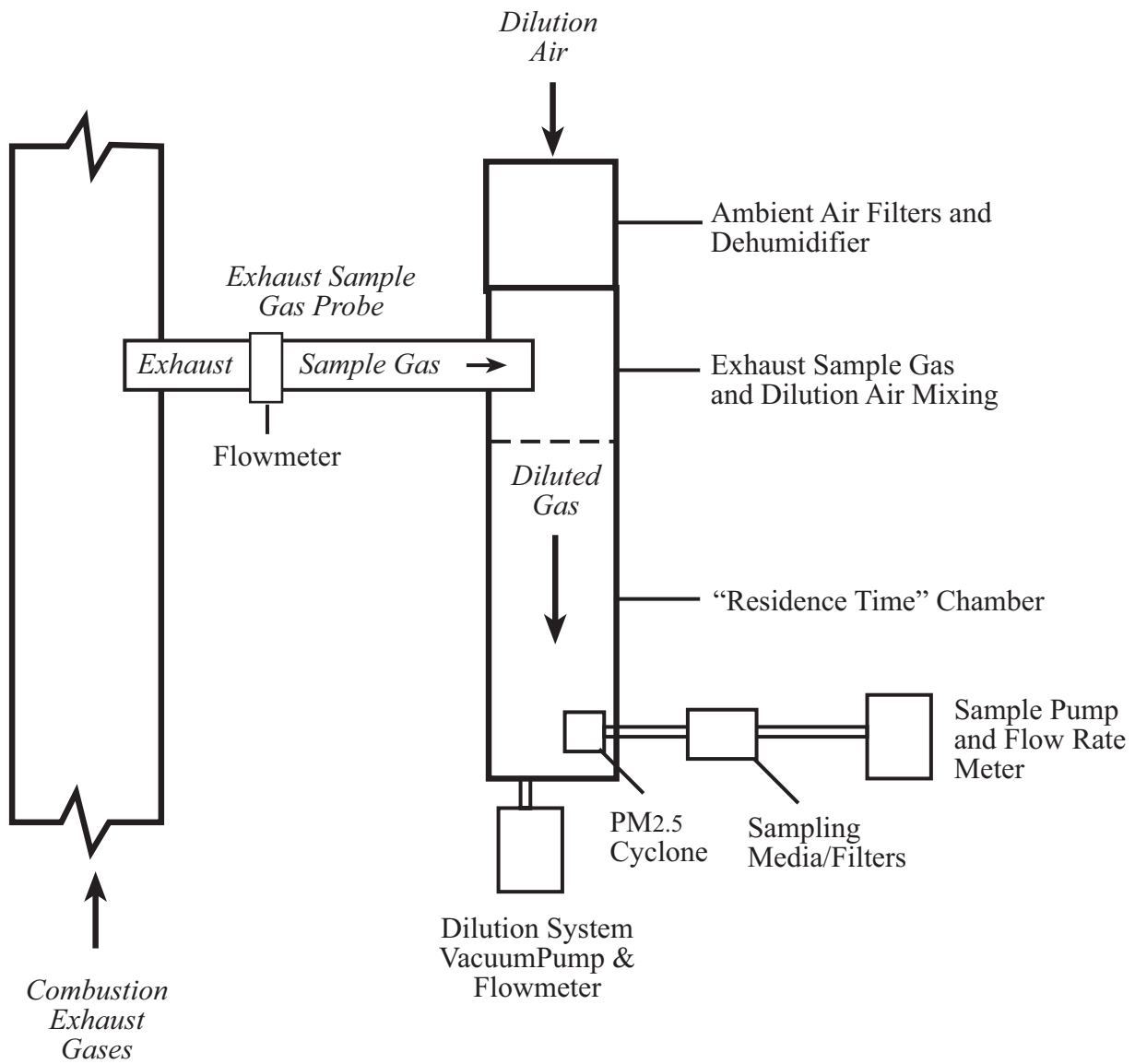

Figure 2. Dilution sampling system schematic

are measured by a Pitot tube traverse of the stack, fuel flow rates and F-factors, or equivalent method.

SIGNIFICANCE AND USE

This test method provides a means of measuring PM_{2.5} mass emissions. This mass emissions measurement method eliminates potential biases associated with other approaches for collecting PM_{2.5} from stationary sources. Hot filtration (in-stack filter) methods (N14) tend to underestimate PM_{2.5} because the hot filter does not collect condensable species. Test methods employing cold aqueous impingers (N15) collect gaseous as well as condensable components and the condensation rate in the impingers greatly exceeds that in the stack plume due to cooling to ambient temperature without dilution. Test data collected using this method are applicable for developing PM_{2.5} emission inventories used in State Implementation Plans for compliance with National Ambient Air Quality Standards for PM_{2.5}, visibility impact assessments, and source-receptor studies related to PM_{2.5} emissions.

PM_{2.5} is respirable and thus a potential health hazard. PM_{2.5} chemical speciation and physical characterization can be determined by applying ambient air sample collection and analysis methods (N3, N4) to the diluted stack sample obtained using this dilution sampling method. These methods can be used to determine VOCs, SVOCs, carbonyls, metals and/or other characteristics of interest.

PM_{2.5} is formed in combustion processes, hot combustion exhaust gases, the cooling exhaust plume as combustion exhaust mixes with the atmosphere, and the atmosphere. PM_{2.5} precursor emissions (e.g., SO₂, NO_x, ammonia, SO₃, HCl, VOC with carbon number greater than 7) can be determined by applying ambient air sample collection and analysis methods to the diluted stack sample (N3, N4). These methods can be used to capture ions, acid gases organics, and/or other species of interest.

INTERFERENCES

The most likely source of PM_{2.5} mass measurement bias is from the handling of the filters. Extreme care must be taken during the loading and unloading of filters to ensure the filters do

not fray or break. It is highly recommended that the loading and unloading of the filter housings be performed in a laboratory, rather than at the testing location. Personnel should wear gloves that are antistatic and powder-free when handling filters. Smooth, non-serrated forceps should be used to handle filters. The forceps should be used for this purpose only, cleaned with alcohol and lint-free wipes, and air-dried prior to use. Teflon membrane filters are required because they are less prone to fraying than glass and quartz fiber filters. The Teflon membrane filters shall incorporate an outer diameter polycarbonate support ring.

Particles may deposit on surfaces of the dilution sampling system and thus may not be collected on the sampling media. The dilution sampler shall be designed to minimize deposition of particles in the sampler prior to the sampling media. Losses in the dilution sampler may be caused by a combination of factors, e.g., thermophoretic losses in the sampling probe, and electrostatic, inertial and diffusional losses in the sampler and tubing connecting sampling media to the sampler. Grounded electrically conductive surfaces should be used to minimize electrostatic losses. The sample probe shall be maintained at a temperature at or slightly above the stack gas temperature to minimize thermophoretic losses. Sharp changes in flow direction shall be avoided to minimize inertial losses.

Liquid water content can impact ambient aerosol size distribution. At ambient relative humidities greater than 70%, particle growth due to accumulation of moisture becomes significant. (N1, N5) Particle size growth from moisture condensation can bias PM_{2.5} measurements if agglomerated particles grow to a size greater than 2.5-micron aerodynamic diameter and are removed by the dilution sampling system prior to the sampling media. Therefore, the diluted air humidity is controlled below 70%.

Liquid water can also impact the weights of collected particulate samples. To minimize this effect, the temperature and relative humidity of the filters weighing chamber are specified to be 22C +/- 3C and 45% +/- 8%, (9.5 deg C dew point +/- 1 deg C) respectively.

Electrostatic charges can bias filter weights. To minimize static charge effects during filter weighings, static charge is neutralized in the weighing chamber prior to weighing by a polonium neutralizer or device of similar effect

Passive deposition of dust on sample filters prior to and following sampling can bias PM_{2.5} measurements. This can be minimized by loading and unloading filter housings in laboratory under controlled conditions and the use of the prescribed filter cassettes.

6.7 Gases may be collected on sampling filters or on particles captured by the filter creating an artifact in the filter weight. The oxidation of acid gases (e.g. SO₂, NO₂) or retention of gaseous nitric acid on the surface of the filter also creates artifacts. These effects can be minimized by the use of Teflon filters that are less prone to gas adsorption than quartz fiber filters.

REQUIREMENTS FOR SAMPLING PLANE AND SAMPLING POINTS

The dilution sampling system sample shall be collected at a location where the exhaust gases are not stratified (N13). The velocity of the stack gas shall be in the range where a PM_{2.5} cyclone can be used (N6). The sample shall be collected from a single point in the combustor exhaust sufficiently far from the wall to eliminate wall flow disturbances.

Convenient access ports and a working platform are required for the testing. See Test Method D 3685/D 3685M for additional criteria.

If flue gas velocity is to be measured using Pitot tube methods (D 3154), the sampling location should have a sufficiently homogeneous gas velocity such that the ratio of the highest to lowest local gas velocities is less than 3:1.

Sampling Plane:

If flue gas velocity is to be measured using Pitot tube (D 3154, N10) or other in-stack methods, the sampling plane shall be situated in a length of straight duct (preferably vertical) with a constant shape and constant cross-sectional area. The sampling shall be conducted as far as practical downstream and upstream from any obstruction that may cause a disturbance and produce a change in the direction of flow (Disturbances can be caused by bends, fans, or control equipment) (N11).

Flue gas velocity measurements at all the sampling points defined in 7.3 shall prove that the gas stream at the sampling plane meets the following requirements:

The angle of gas flow is less than 15° with regard to the duct axis (method for estimation is indicated in Annex C of ISO 10780);

No local reverse flow is present;

The minimum velocity is measurable by the test method used (for example, using Test Method D 3154, a differential pressure larger than 5 Pa); and

The ratio of the highest to lowest local gas velocities is less than 3:1.

If the above requirements cannot be met, the sampling location will not be in compliance with this test method for measuring flue gas velocity with a Pitot tube and alternative methods should be considered.

Minimum Number and Location of Sampling Points for measuring flue gas velocities:

See Test Method D 3154, Section 8, Figs. 7 and 8, and Tables 1 and 2.

Access Ports:

Provide sampling ports for access to the sampling points selected, in accordance with 7.3 and Test Method D 3154.

Ensure that the port dimensions offer ample space for the insertion and removal of the sampling equipment and associated devices.

VELOCITY AND GAS COMPOSITION MEASUREMENT APPARATUS

See Section 6, Test Method ASTM D 3154

SAMPLING APPARATUS

Exhaust Gas Sample Probe – Stainless steel probe with diameter between 10 mm and 13 mm equipped with an in-stack PM_{2.5} cyclone constructed per EPA Method PRE-004 requirements (N6). Wall temperature maintained between 120C and 315C. If the stack gas temperature is

greater than 315C, then sample pre-dilution in the probe is needed to reduce sample gas temperature below 315C.

Exhaust Gas Sample Transfer Line (Optional, not recommended – only used if port logistics do not allow a direct connection of the probe and dilution system) – Constructed of stainless steel or copper tube and shall be as short as possible and equal or greater than probe diameter, but no more than 13 mm. Sample transfer line shall be insulated and heated to a minimum wall temperature of 150C.

Dilution Air High Efficiency Particulate Arresting (HEPA) filter - designed for air flows to give dilution ratios of 20:1 to 30:1. HEPA filters shall have a minimum filtering efficiency of 99.97% when tested at an aerosol of 0.3 microns diameter (N7).

Dilution Air Activated carbon bed or filter (Optional – Recommended if samples for analysis of organic compounds will be collected or if ambient air has high VOC concentrations.) Design for air flows to give dilution ratios of 20:1 to 30:1.

Dilution Air Dehumidifier (optional) - designed for air flows to give dilution ratios of 20:1 to 30:1 and diluted gas humidity less than 70 % at temperatures less than 52C.

Dilution Air Heater (optional) - designed for air flows to give dilution ratios of 20:1 to 30:1 and diluted gas temperatures less than 52 C.

Dilution sampling system mixer/residence time chamber – with following specifications:

The inlet will be the point of mixing between the dilution air and exhaust gas sample. Mixing must be rapid with completeness verified by measurement of the downstream CO₂ profile at a minimum of four points with a maximum difference of 10% between any two traverse points. Mixer designs can include jet entrainment, mixing orifice, venturi, or equivalent.

The minimum residence time shall be 10 seconds after mixing is complete (N12). Flow capacity of dilution system shall be sufficient to for a minimum 20:1 dilution ratio. Larger dilution ratios may be required to completely eliminate water condensation in dilution and sampling systems

and maintain temperature of diluted exhaust at 47 Deg C +/- 5 deg C immediately upstream of the residence time chamber's PM2.5 cyclone(s).

Constructed of electrically conductive, unreactive materials such as stainless steel. The system shall be electrically earthed to prevent electrostatic effects and designed to minimize deposition or alteration of the particulates

Temperature control system (Optional) – Insulation or heating may be required to maintain target temperature range.

Dilution air vacuum pump with sufficient capacity to maintain specified dilution air flows.

PM2.5 Sampling System

Stainless steel PM2.5 cyclone(s) - constructed per EPA Method PRE-004 requirements (N6) and with sufficient flow rate for all sampling media.

Probe – The probe from the PM2.5 cyclone should be designed to minimize PM deposition (gradual bends if any), constructed of electrically conductive material (one inch stainless steel tube is recommended) that will not react with gas constituents, and electrically grounded. The probe may be heated to no more than 52C before exhaust gas is introduced to DT and may be insulated. The probe shall be as short as possible and no more than 1.02 m length (probe tip to filter or sampling manifold).

Filter packs – constructed of glass, Teflon, or other inert material with minimum 47 mm stain area. Recommended loading of 465 ug/mm² (0.5 mg/1075 mm²) stain area: 0.5 mg on 47 mm filter; 1.3 mg on 70 mm filter; 2.3 mg on 90 mm filter; 3.6 mg on 100 mm filter. The filter packs may be heated or insulated to maintain a temperature range of

Sample Flow Measurements – Sample gas flow shall be determined with flow measurement devices accurate to at least +/- 4%

Particulate Filter Analysis System.

Analytical balance with precision: Filter size <70 mm: 1 ug; Filter size 70 mm and above: 10 ug; and resolution: Filter size <70 mm: 1 ug; Filter size 70 mm and above: 10 ug. The balance should be in climate-controlled area with temperature and humidity controls and meters.

System shall be electrically earthed to prevent electrostatic effects.

Humidity meter.

Static charge neutralizer – polonium neutralizer or device of similar effect.

REAGENTS AND MATERIALS

- Purity of Reagents—Reagent grade chemicals shall be used in all tests. All reagents shall conform to the specifications of the committee on Analytical Reagents of the American Chemical Society. (N8)
- Purity of Water—Unless otherwise specified, water shall be Type III reagent water conforming to Specification D 1193.
- Determine reagent blanks on the acetone and reagent water.
- Acetone—Reagent ACS grade acetone with # 0.001 % residue in glass bottles. Acetone supplied in metal containers is unacceptable due to the prevalently high residue levels. Reject the acetone if blank residue mass (see 10.3) is >0.001 % of the total acetone mass.
- Soap
- Kimwipes
- Towels
- Brushes to clean sample probes and lines.
- Teflon tape
- Petri dishes for filters

- Shipping containers and materials for filters/petri dishes
- Gloves, insulated, heat-resistant.
- Teflon membrane filter. The filters shall exhibit at least 99.95 % collection efficiency of a 0.3-mm dioctyl phthalate smoke particle, in accordance with Practice D 2986. The manufacturer's quality control test data are sufficient for validation of efficiency. Check the filters for irregularities, flaws, or pinholes by holding them up against a light source.

WEIGHING AND PRE-SAMPLING PROCEDURE

General Aspects

Before carrying out any measurements, discuss the purpose of the sampling and the sampling procedures with the plant personnel concerned. The nature of the plant process, for example, steady state or cyclic, can affect the sampling program. If the process can be performed in a steady state, it is important that this state be maintained during sampling

Agree upon, with the plant management, the dates, starting times, duration of survey, and sampling periods as well as plant operating conditions during these periods.

Make preliminary calculations on the basis of the expected particulate loading to determine the appropriate nozzle size/sample rate or sampling conditions, or both. Also determine whether the chosen nozzle size and sampling time will result in sufficient matter collected to meet weighing requirements. Longer sampling times or sampling with the use of a larger nozzle and higher sample flow rates may be necessary to obtain the sample filter mass sufficiently greater than the blank filter mass.

Take a tunnel blank sample after each measurement series following the procedure described in 13.8.3. This blank sample leads to an estimation of the dispersion of results related to the whole procedure as carried out by the operators for a near zero dust concentration, due to contamination of filters and of rinsing solutions during handling on-site, transport, storage, handling in the laboratory, and weighing procedures, and so forth.

Weighing Procedures:

- Weigh the filter on a suitable balance (see 9.9.1).
- Before each weighing series calibrate the balance against standard weights.
- Adjust filter weighing chamber temperature to 22C +/- 3C.
- 11.2.4 Adjust filter weighing chamber relative humidity to 45% +/- 8% (dew point 9.5 Deg C +/- 1 deg C).
- Record the climatic conditions in the room.
- Static charge shall be neutralized prior to weighing by a polonium neutralizer or device of similar effect
- Filter weighing chamber shall be free of any ambient contaminants (such as dust) that could settle on filters during stabilization.
- Filters shall be conditioned for at least 1 hour, but no more than 80 hr, before weighing.
- If the filter weighing chamber environmental conditions are not met, then the filters shall remain in the conditioning room for at least one hour after correct conditions are met prior to weighing.
- At least two reference filters shall be weighed within four hours of sample filter weighings. If the average mass of the reference filters changes between sample filter weighings by more than 5% of the recommended minimum filter loading (refer to 9.8.3), then flag data and report deviation in reference filter weights.

SAMPLING

Preparation:

- Clean (brush and rinse), calibrate, and check all the equipment before moving it to the test site. Exercise care not to reuse any part of a sampling train that has previously been used for high particulate concentration sampling without dismantling and thorough cleaning.

- Depending on the measurement program, prepare the filters to be weighed for each sample run. This includes filters for the blank tests and additional filters to accommodate process and equipment malfunctions.
- Perform the weighing procedures according to 11.3.
- Protect all the weighed filters and the other parts or equipment that will come into contact with the sample from contamination during transportation and storage.

Pre-Sampling Measurements:

- Depending on the dimensions of the duct, which are to be verified using a measuring rod, surveyor's transit, or other means, select the location of the sampling point according to 7.1. If flue gas flow rates are to be measured using a Pitot tube, select the number and location of sampling points, according to 7.3 and Test Method D 3154. Mark on the Pitot tube the distance from the sampling points to the entry point of the access port.
- Determine the temperature, pressure, moisture content, and molecular weight of the flue gas at the sampling location in accordance with Test Method D 3154, in order to correct emissions data from actual to standard conditions. At a minimum, measure these parameters pre- and post-test to determine if they vary spatially or temporally during the period of the test.
- Taking into account the preliminary calculations (11.1) and the measured velocities, select a suitable nozzle for sampling as close to the isokinetic rate as possible while sampling at the correct flow rate for the in-stack PM2.5 cyclone.

Sampling:

- Assemble the dilution sampling system in the cleanest possible area, without grease or other organic sealers. Check for possible leaks (procedure to be defined);
- Collect flue gas flow measurement data either before and after, or during flue gas sampling, whichever is appropriate for method used. Exhaust flow may be measured by Pitot tube traverse per US EPA Method 2 or ASTM D 3154; stack oxygen and fuel flow and composition measurement (US EPA Method 19); carbon balance method (ISO 8178-1 Annex A); or other equivalent method.
- Place the sample probe nozzle at the center of the exhaust duct or at a sufficient distance from the duct wall such that there are no flow disturbances after measuring the flue gas velocity at sampling point. Avoid contacting the nozzle with any deposits within the duct.

Seal the opening of the access port to minimize air in-leakage or exposure of operators to toxic gases;

- Turn on pump to start the dilution air flow
- Preheat the exhaust gas sample probe to the specified temperatures (9.1). After minimum probe temperatures are achieved, start the exhaust gas sample flow. Sample gas flow rate to be pseudo – isokinetic, as close to the isokinetic rate as possible while sampling at the correct flow rate for the in-stack PM_{2.5} cyclone. Adjust the dilution air flow rate to target dilution ratio (**Section 9.3**. The dilution ratio shall be a minimum of between 20:1 and 30:1. Larger dilution ratios (up to 30:1) may be used if required to completely eliminate water condensation or to lower the temperature of the diluted exhaust gas to less than or equal to 52C at the PM_{2.5} cyclone(s) upstream of the filter holders. If dilution ratios greater than 30:1 are required, the minimum dilution ratio necessary to achieve the maximum humidity and maximum temperature criteria should be used. Adjust temperature of dilution air as needed. Adjust humidity of dilution air to a diluted sample gas relative humidity of 70% or less.
- Verify dilution ratio – Methods include: 1.) Direct measurement of flows (sample exhaust gas, dilution air, total diluted air - at least 2 of the 3 needed); 2.) Measurement of CO₂ or NO_x in sample exhaust gas, dilution air, total diluted air and calculation of dilution ratio via mass balance; 3.) From carbon balance by measuring CO₂ and fuel composition and flow.
- After dilution tunnel conditions have equilibrated, turn on PM filter sample system pump and adjust flow to target rate. Filter face velocity should be less than 100cm/sec)
- Collect PM on filter for target sampling time. Record dilution tunnel and sample system operating conditions (temperature, flow rates, humidity, dilution ratio) at a minimum of 12 equally spaced intervals during each test.
- After PM sampling is completed, turn off sampling pump and record final sample volumes and/or flow rates. Shut down dilution sampling system flows after recording final operating conditions. Perform post-test leak check.
- Recover sample filter holders with filters intact, seal containers tightly, and affix sample label with unique number to each sample. Record sample information on sample tracking form. Pack samples for shipment or transfer to lab. The container material shall be sufficiently electrically conductive to avoid dust losses from the filter due to electrostatic charge effects.
- Inspect sample lines for condensed material, record observations.

Recovery of Deposits Upstream of the Filter

- A clean environment is recommended for the following procedure. Exercise special care to avoid contamination of the sample if the procedure is performed on-site.
- Rinse with water the sample probe components that are in contact with the sample gas upstream of the filter to recover the deposits. Collect the rinse into a storage bottle and allow no external dust to fall into the bottle. Rinse these same surfaces with acetone and collect the acetone into the same bottle.
- Do not mechanically clean surfaces to recover deposits upstream of the filter after sampling. However, it is necessary to mechanically clean and rinse the equipment before the next measuring series is initiated.

Validation of Results

- Parameters Depending on the Stationary Source
- If testing was conducted at an unsuitable location or was carried out under fluctuating plant operating conditions, the representativeness of the sample may be questioned and the measurement results uncertain. In such cases, the test report shall clearly indicate that the test was not conducted according to the specifications of this test method.
- Include in the test report details of the flow characteristics at the sampling location or on the variations of the flow rate in the duct while sampling, or both.

Leak Check:

Significant errors may be caused by leaks in the sampling train, especially in parts that are under vacuum. Therefore, before and after each test, leak test the sample probe and filter by sealing the probe and starting the suction device. The flow rate shall be at most 2 % of the normal flow rate at the maximum vacuum reached during sampling, otherwise the measurement is not valid should be flagged.

CALIBRATION AND QA/QC ACTIVITIES:

- Calibrate the velocity and gas composition measurement apparatus according to Test Method D 3154.

- Exhaust gas sample flow meters – Calibrate sample flow rate meters at least every six months or whenever a system repair or change is made that could influence calibration. Meter should be calibrated against an NBS traceable standard and agreement should be within +/- 4% of reading. Calibration of gas flow measurement instruments shall be traceable to international and/or national standards.
- PM sample system flow meters - Calibrate sample flow rate meters at least every three months or whenever a system repair or change is made that could influence calibration. Meter should be calibrated against an NBS traceable standard and agreement should be within +/- 4% of reading.
- Analytical balance precision: Filter size <70 mm: ± 1 ug; Filter size 70 mm and above: ± 10 ug.
- Analytical balance resolution: Filter size <70 mm: 1 ug; Filter size 70 mm and above: 10 ug.
- Temperatures - Calibrate thermocouples at least every three months or whenever a system repair or change is made that could influence calibration. Thermocouple should be calibrated against an NBS traceable standard and agreement should be within +/- 2 K.
- Relative humidity meters – calibrate relative humidity meters at least every month or whenever a system repair or change is made that could influence calibration. Meter should be calibrated against an NBS traceable standard and agreement should be within +/- 3% of reading

QA/QC Activities

- Pre-test dilution sampling system cleaning (before each test condition) - Wash and rinse all components with acetone. Wipe down large surfaces.
- Pre-test dilution sampling system blank – One per test condition. Filtered dilution air is drawn through the dilution sampling system without exhaust gas and samples are collected.
- Ambient Air Sample – One per sampling location. Collected at sampling location by directly pulling unfiltered ambient air samples through sampling media.
- Field blank – Collected by assembling and disassembling sampling equipment without drawing any gas through the media.
- Leak checks per 12.6.2.

- Check dilution ratio. The measured dilution ratio in the diluted exhaust gas shall be within 10% of the dilution ratio calculated from CO₂ or NO_x concentrations measured in the combustion exhaust and dilution sampling system exhaust.
- Verify that the gases in the dilution sampling system are uniformly mixed - Mixing must be rapid with completeness verified by measurement of the downstream tunnel CO₂ profile at a minimum of four points with a maximum deviation of 10% between any two traverse points.

ADDITIONAL ASPECTS DISCUSSION

Sampling Duration and Detection Limit:

Where possible, extend the sampling time, which decreases the detection limit.

Particulate Deposits Upstream of the Filter:

- Errors can be introduced into the measurements if particulate deposits upstream of the filter are not recovered carefully.
- Particulate deposits are dependent upon the design of the sampling equipment and the characteristics of the particulate matter to be sampled. Therefore, check all non-weighed parts for the deposition of particulate matter, if present, collect the particulate matter.
- Deposits may be collected by the rinsing procedures in 12.4.

Improvement of the Weighing Procedure:

- Experience has shown that weighing uncertainties are not only related to the balance performance but to the whole procedure employed. Therefore, before performing any measurement, the user shall establish and validate a procedure, taking into account the sampling equipment and filters to be used.
- Repeated weighing of the same parts, spread over several weeks in various conditions, that is, external temperature, humidity, and so forth, will provide an estimation of the actual precision of weighing, including the uncertainties related to the manipulation of the filters, equilibrium time, and so forth.
- Use the results as a first estimate of the overall blank value, and provide a means of calculation of the gas volume to be sampled in order to obtain significant data, taking into account the anticipated range of particulate concentrations.

CALCULATIONS

Stack Gas Flow Rate

Q_s = stack gas flow rate, scm/min.

Where:

scm/min = standard cubic meters per minute

DR = dilution ratio

Calculated from tracer gas measurements

- Future.

Calculated from direct flow measurements.

$DR = Q_{DEX}/Q_{EX} = (Q_{DA} + Q_{EX})/Q_{EX}$, where:

- Q_{DEX} is the flow rate of the diluted exhaust gas at standard conditions, $scm/min = Q_{MDEX} * (T_{STD}/T_M)*(P_M/P_{STD})$, where:
- Q_{MDEX} is the measured diluted exhaust gas flow rate, cm/min;
- T_{STD} is the standard conditions temperature, K;
- T_M is the measured diluted exhaust gas temperature, K;
- P_{STD} is the standard conditions pressure, in Hg;
- P_M is the measured diluted exhaust gas pressure, in Hg;
- cm/min = cubic meters/min.
- Q_{DA} is the flow rate of the dilution air at standard conditions, $scm/min = Q_{MDA} * (T_{STD}/T_M)*(P_M/P_{STD})$, where:
- Q_{MDA} is the measured dilution air flow rate, cm/min;
- Q_{EX} is the flow rate of the exhaust gas sample at standard conditions, $scm/min = Q_{MEX} * (T_{STD}/T_M)*(P_M/P_{STD})$, where:

- Q_{MEX} is the measured exhaust gas sample flow rate, cm/min;

PM2.5 Concentration in Stack Gas

$C_{PM2.5}$ = PM2.5 Concentration in Stack Gas, mg/scm = $DR * (M_{FP} - M_{FT}) / V_{FSTD}$, where

- M_{FP} is the mass of the particulate laden filter(s), mg;
- M_{FT} is the tare mass of the filter(s), mg;
- V_{FSTD} is the volume of the diluted exhaust gas that passed through the filter corrected to standard conditions = $V_F * (T_{STD}/T_M) * (P_M/P_{STD})$, scm, where:
- V_F is the measured volume of diluted exhaust gas that passed through the filter, cm;
- cm = cubic meters.

PM2.5 Mass Emission Rate

$M_{PM2.5}$ = PM2.5 mass emission rate = $C_{PM2.5} * Q_s * 60 * 10^{-6}$, kg/hr.

PRECISION AND BIAS

General:

Because the flue gas composition may vary in the time, it is not possible to determine the repeatability and reproducibility of the test method according to Guide D 3670.

However, if one team performs successive parallel sampling tests with two identical sampling systems, such a procedure allows a statistical comparison between paired values x_1 and x_2 to be calculated.

The standard deviation of the differences can be calculated as follows:

- $S = (\text{sum of } ((x_1 - x_2)^2) / 2n)^{0.5}$; where

- n, the number of sample pairs, may be used for the calculation of the repeatability confidence interval $r = t \cdot (2S)^{0.5}$, where t is the Student factor for a 95 % confidence and the degrees of freedom n-1.

The repeatability, r, (according to ISO 5725), that is the maximum difference between two measurements by the same team, for a 95 % confidence level is:

- $r = t \cdot s \cdot 2^{0.5}$

When data are provided by several independent teams operating together, similar calculations can be conducted and provided as an estimation of:

The external uncertainty linked to an individual measurement carried out by any team fulfilling the requirements of the test method; and

The reproducibility (according to ISO 5725), that is the maximum difference, R that can be expected at a 95 % confidence between two measurements by different teams working according to the test method at the process conditions.

When performing measurements at low-level concentrations, the detection limit may be estimated:

By parallel measurements and calculation of the uncertainty; and

By successive measurements at near zero concentration. The detection limit is assumed to be three times the standard deviation.

TEST REPORT

The test report shall refer to this test method and shall include the following information:

- Description of the purpose of tests, identification of the site, date of sampling, and participants in the test.
- Description of the operating conditions of the plant process and any variation during measurements.
- Identification of the sampling location and gas parameters in the duct.

- Duct dimensions, number and position of velocity measurement lines, and sampling point;
- Velocity and temperature profile;
- O₂/CO₂ (if relevant), humidity concentrations, gas volumes; and
- Measurement Procedures:
 - Velocity measurement (calibration of S Pitot tubes, and so forth);
 - Characteristics of sampling equipment: (a) Make (type, manufacturer) of the sampling system; (b) Nozzle diameter, characteristic of filter (material, size, type); (c) Calibration of flow rate measurement devices; and (d) Filtration temperature.
 - Weighing procedures: (a) Conditioning temperature and humidity; and (b) Correction of the apparent mass.
- Test Results:
 - Number, date, duration of tests for each test: (a) Mass of PM_{2.5} collected; (b) Temperature and pressure of the gas in the dilution sampling system; (c) Dilution ratio and gas composition (including moisture content); (d) Sampling time; (e) Sampled volume and flow rate; (f) Any special circumstances or incidents; (g) All intermediate and final calculation results; and (h) Raw results and corrected results (standard conditions).
 - Quality Assurance:
 - Leak tests results,
 - Blanks value, and
 - Deposits of dust upstream of the filter.
 - Comments:

Indicate in the test results, the value of the ratio of the measured values to the blanks values.

Also indicate in the test report any special circumstances that may have influenced the results and any information concerning the uncertainty of the results.

If it has been necessary to modify the test method for any reason, report this modification.

KEYWORDS

PM2.5; dilution system sampling; stack sampling

SAFETY PRECAUTIONS

Collection of emissions samples may require working on stack platforms and other elevated surfaces. General safety precautions for working at elevation are specified in the Source Evaluation Society Safety Guidelines Book (N9).

Protective clothing (heavy long sleeves and pants, hard hats, and eye protection) should be worn at all times while working in the vicinity of combustion systems that have hot surfaces.

Insulated gloves should be worn when handling hot probes or accessing combustor vents with hot surfaces. Hearing protection should be worn if noise levels exceed 80 decibels.

Equipment cleaning requires the use of acetone. This work should be performed in a well-ventilated area to minimize workers exposure to acetone fumes. Workers should wear gas masks with organic filters if ambient levels exceed (TBD) as determined by (TBD).